











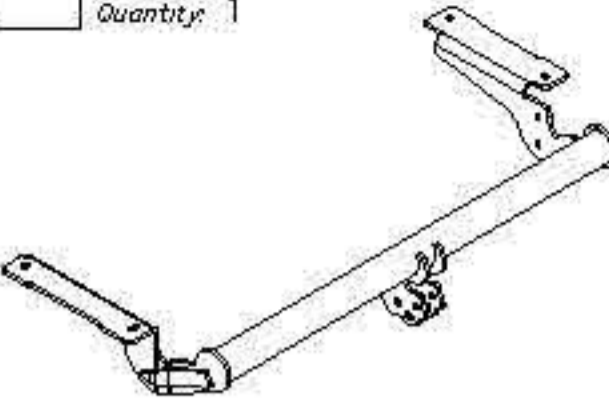

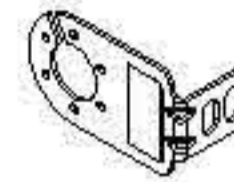
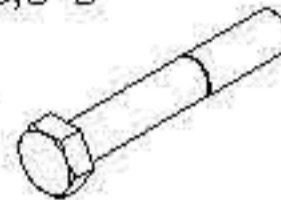

S.C. AUTO GEDAL IMPEX S.R.L.

Tel: +40 745.805.990 / +40 737.122.471

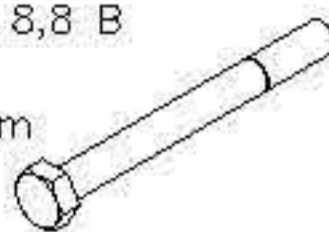
Email: autogedal@gmail.com
office@auto-hak.ro

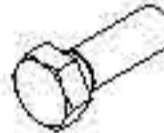
Web Page: www.auto-hak.ro

Towbar accessories:

Pos. 1 Name: Main bar Quantity: 1 	Pos. 5 Name: Right fish-plate Quantity: 1 Dim.: 295x112x5mm 	Pos. 11 Name: Nut 8 B Quantity: 6 Dim.: M10 
Pos. 2 Name: Tow ball Quantity: 1 	Pos. 6 Name: Distance sleeve Quantity: 4 Dim.: Ø17,2x2,35; L=88mm 	Pos. 12 Name: Plain washer Quantity: 2 Dim.: Ø 13 mm 
Pos. 3 Name: Socket plate Quantity: 1 	Pos. 7 Name: Bolt 8,8 B Quantity: 2 Dim.: M12x75mm 	Pos. 13 Name: Plain washer Quantity: 6 Dim.: Ø 10,5 mm 
Pos. 4 Name: Left fish-plate Quantity: 1 Dim.: 310x110x5mm 	Pos. 8 Name: Bolt 8,8 B Quantity: 4 Dim.: M10x120mm 	Pos. 14 Name: Spring washer Quantity: 2 Dim.: Ø 12,2 mm 
	Pos. 9 Name: Bolt 8,8 B Quantity: 2 Dim.: M10x35mm 	Pos. 15 Name: Spring washer Quantity: 6 Dim.: Ø 10,2 mm 
	Pos. 10 Name: Nut 8 B Quantity: 2 Dim.: M12 	Pos. 16 Name: Ball cover Quantity: 1 

Towing hitch (without electrical set)

Class: A50-X Cat. no. E23

Designed for:

Manufacturer: OPEL

Model: ASTRA "G"

Type: ESTATE

produced since 03.1998 till 10.2004

Technical data:

D-value: 8,6 kN

maximum trailer weight: 1500 kg

maximum vertical cup load: 75 kg

Approval number acc. to regulations EKG/ONZ 55.01: E20-55R-01 0734

Foreword

This towbar is designed according to rules of safety traffic regulations. The towing hitch is a safety component and can be install only by qualified personnel. Any alteration or conversion of the towing hitch is prohibited and would lead to cancellation of design certification. Remove insulating compound and underseal from vehicle (if present) in the area of the matting surfaces of the towing hitch.

The vehicle manufacturer's specifications regarding trailer load and max. vertical cup load are decisive for driving, and values for the towing hitch cannot be exceeded.

D-value formula:

$$\frac{\text{Max trailer weight [kg]} \times \text{Max vehicle weight [kg]}}{\text{Max trailer weight [kg]} + \text{Max vehicle weight [kg]}} \times \frac{9,81}{1000} = D \text{ [kN]}$$

FITTING INSTRUCTION

Clamp mark in acc. with		Cables joining
ISO	PN	
1	L	Left directional lights
2	+	Rear fog lights
3	31	Ground
4	R	Right directional lights
5	58R	Right side parking lights
6	54	Stoplights
7	58L	Left side parking lights

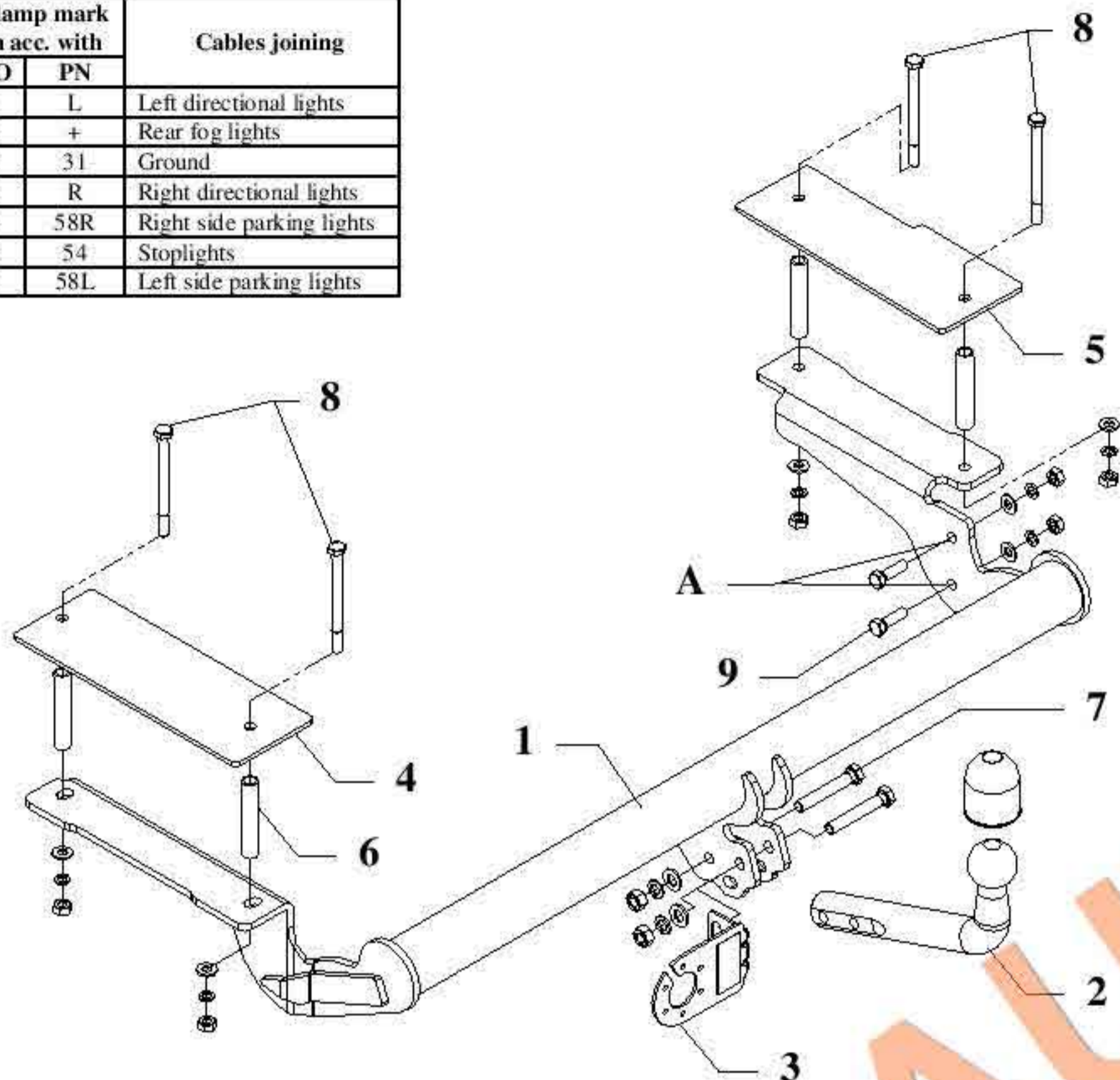

This towbar is designed to assembly in following cars:
OPEL ASTRA "G" ESTATE, produced since 03.1998 till 10.2004,
 catalogue no. **E23** and is prepared to tow trailers max total weight **1500 kg**
 and max vertical load **75 kg**.

From manufacturer

Thank you for buying our product. Their reliability has been confirmed in many tests. Reliability of towbar depends also on correct assembly and right operation. For this reasons we kindly ask to read carefully this instruction and apply to hints.

The towbar should be install in points described by a car producer.

INSTRUCTIUNI MONTAJ

1. Demontați bara de protecție și capacele panel`'s spate și laterale (În interiorul cizme), apoi trage mocheta din spate.
2. Demontați amortizor de zgomot și panoul termic.
3. Găsiți trei găuri marcate pe partea stângă și dreaptă, apoi burghiu două găuri (prima și ultima) folosind $\varnothing 17\text{mm}$.
4. Puneți mâneci (poz. 6) și pește plăcile (poz. 4 și 5), prin aceste găuri, și apoi puneți $\times 120\text{mm}$ șuruburile M10 (poz. 8).
5. Poziționați bara principală a barei de remorcare (poz. 1), în partea de jos a mașinii, și apoi se potrivesc.
6. Se montează inelul de remorcare prin eye`s de remorcare găurile de tesatura, iar găuri (poz. A). Folosiți șuruburi M10x35mm (poz. 9).
7. Demontați spuma din bara de protecție, apoi se taie bara de protecție mică și reasamblați bara de protecție
8. Se fixează bila bara de remorcare (poz. 2) cu placa de soclu (poz. 3), utilizând M12x75mm (poz. 7) șuruburi de accesorii bară de tractare.
9. Reasamblați amortizor de zgomot și capacul termic.
10. Strângeți toate piulițele și șuruburile conform cu cuplul este prezentat în tabel.
11. Conectați cablurile electrice în conformitate cu instrucțiunile mașinii.

Torque settings for nuts and bolts (8,8):

M6 - 11 Nm	M8 - 25 Nm	M10 - 50 Nm
M12 - 87 Nm	M14 - 138 Nm	M16 - 210 Nm

NOTE

After install the towbar you should get adequate note in registration book (at authorised service station). The car should be equipped with:

- Indicators
- Tow mirrors

After 1000km of exploitation check all bolts and nuts. The ball of towbar must be always kept clear and conserve with a grease.