



FORD MONDEO V
saloon, estate, htb.
(excl. hybrid drive)

09/2014 -

Cat. No. E/A57

E20 E20*55R01/07*005967*00

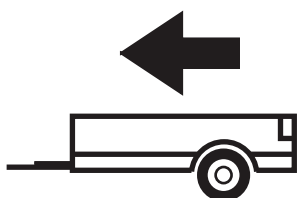

2532kg

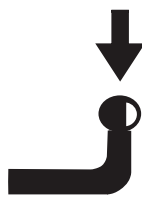

100kg

D = 11,90kN

$$D \text{ (kN)} = \frac{\text{MAX kg} \times \text{MAX kg}}{\text{MAX kg} + \text{MAX kg}} \times 0,00981$$



IMIOLA HAK-POL

96-111 KOWIESY, CHOJNATA 23A, POLAND

Tel. + 48 46 831 73 31, fax +48 831 74 29

e-mail: office@imiola.pl, www.imiola.pl

PRZEKRÓJ A-A

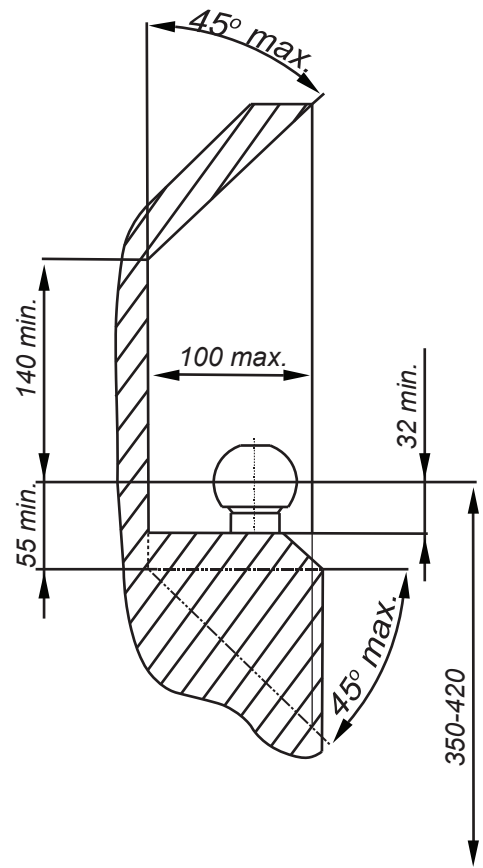
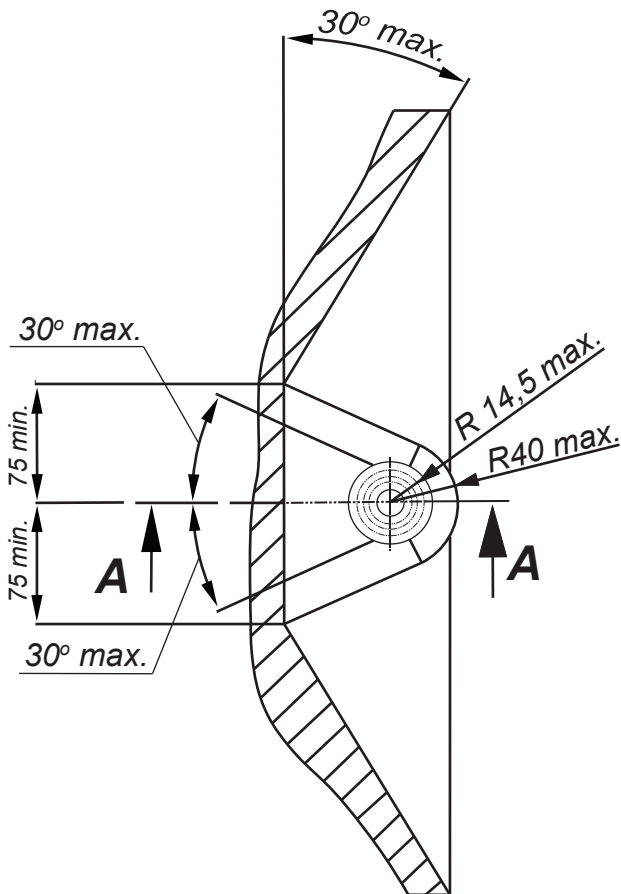

PL Należy zagwarantować przestrzeń swobodną według załącznika VII, rysunek 25a/b Regulaminu EKG ONZ 55.01 przy dopuszczalnym ciężarze całkowitym pojazdu.

F L'espace libre doit être garanti conformément à l'annexe VII, illustration de la réglementation 55.01 CE pour un poids total en charge autorisé du véhicule.

GB The clearance specified in appendix VII, diagram 25a/b of Regulation No. 55.01 UN EU must be guaranteed at laden weight of the vehicle.









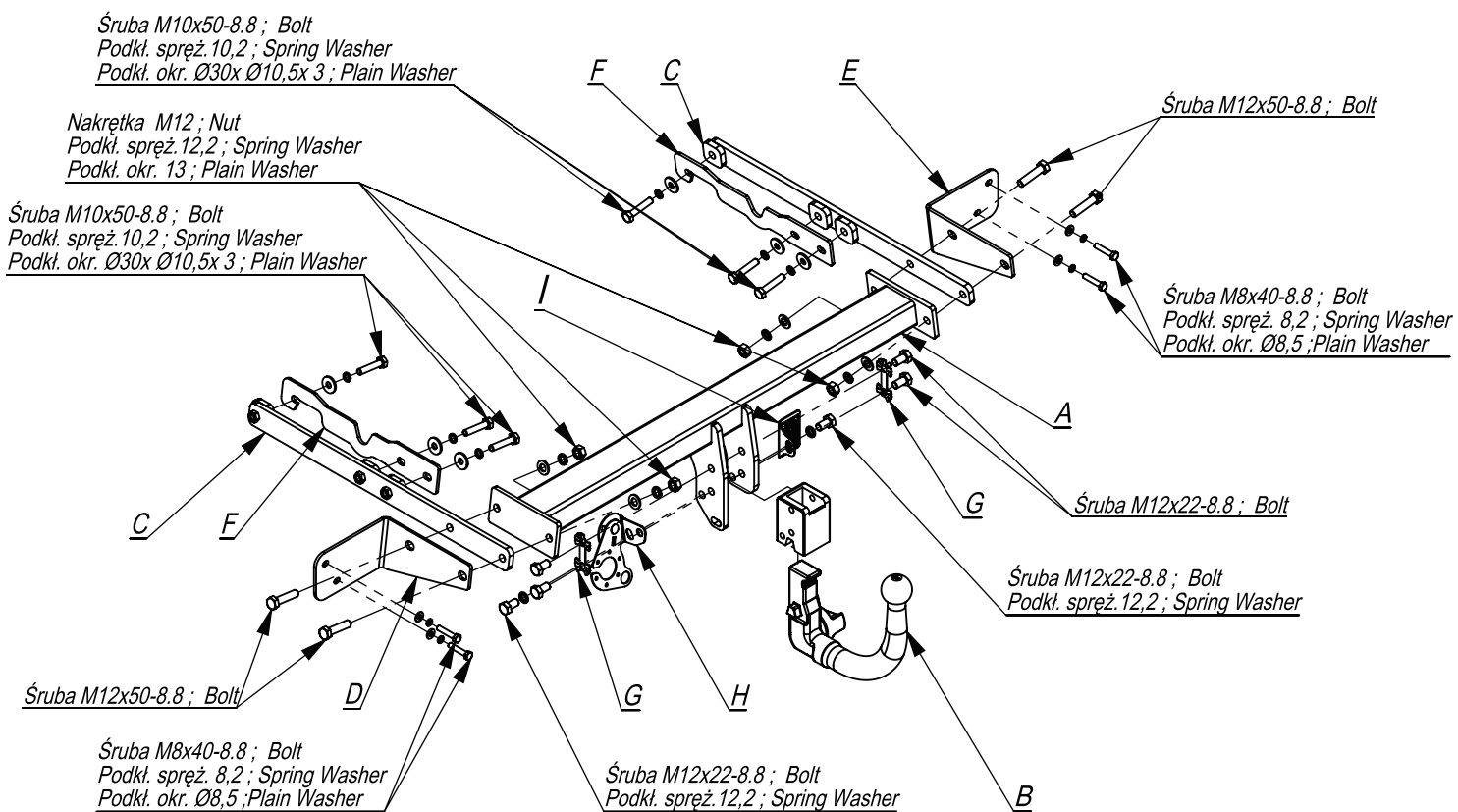

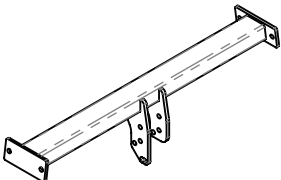
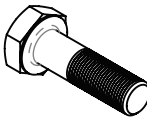
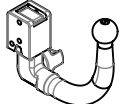

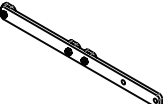
D Der Freiraum nach Anhang VII, Abbildung 25a/b der Vorschriften 55.01 EG ist zu gew 25a/bahrleiten bei zulässigem Gesamtgewicht des Fahrzeuges.

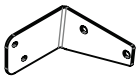
Moment skrecający dla śrub i nakrętek (8.8) Torque settings for nuts and bolts (8.8)

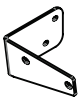
M8	25Nm
M10	55Nm
M12	85Nm
M14	135Nm
M16	195Nm





	A	x1		M12x50	4
				M12x22	6
				M10x50	6
				M8x40	4
	B	x1		M12	4
	C	x2		Ø30xØ10,5x3	6
	D	x1		13	4
	E	x1		8,5	4
	F	x2		12,2	6
				10,2	6
				8,2	4
	G	x2			
	H	x1			
	I	x1			

